



**LINK**<sup>®</sup>  
we link the world

BAĞLANTI ELEMANLARI VE DİŐLİ AKSESUARLAR  
*CONNECTION ELEMENTS AND THREADED ACCESSORIES*



ENDÜSTRİYEL ASKI VE DESTEK SİSTEMLERİ

[www.linkyapi.com.tr](http://www.linkyapi.com.tr)

Bağlantı elemanları ve dişli aksesuarlar; Boru hatlarındaki yükleri ve kuvvetleri yapıya aktaran modüler sistemlerdir. Yapısal çeşitliliğe bağlı olarak ayarlanabilir ve alternatifli modeller, en efektif çözümleri sağlar.

Boru hatları ve ekipmanlarının çalışma ve ortam koşullarına en uygun ürün seçilmelidir. Katalog ürünleri dışında özel ölçülerde üretim yapılabilir. Boru ve ekipmanlarının maruz kalabileceği tüm statik ve dinamik çalışma koşullarını karşılayacak emniyette tasarlanmış olmalıdır. Bu aşamada seçim analizlerinin yapılabilmesi için mühendislik ekibimizden destek alabilirsiniz.

**Connection and threaded accessories used to transfer the pipe loads and forces to the structures. These elements can be adjusted in accordance to the structural models and alternative types.**

**The products should be selected suitable to the pipe lines and equipment's. The products can be also custom designed if the sizes are not available in catalogs. The supports should be designed with a safety factor that stands all the dynamic and static loads. In all these stages, in order to have an accurate selection, you can consult our engineering team.**

#### İLGİLİ STANDARTLAR / RELEVANT STANDARDS

ASME B31.1-31.3 Enerji ve proses borulama.

ASME B31.1-31.3 Energy and process piping

MSS.SP.58. Boru askı ve destekleri, malzeme, tasarım ve imalat.

MSS.SP.58. Pipe hangers, supports, materials, design and manufacturing

MSS.SP.69- Boru askı ve destekleri, seçim ve uygulama.

MSS.SP.69- Pipe hangers and supports, selection and application.

BS.EN 13480-Endüstriyel borulama ,tasarım ve seçim.

BS.EN 13480-Industrial piping, design and selection

BS.EN.ISO.9001. Kalite yönetim sistemi.

BS.EN.ISO.9001. Quality Control

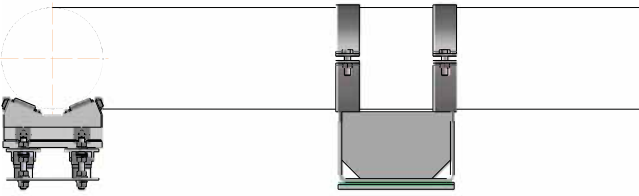
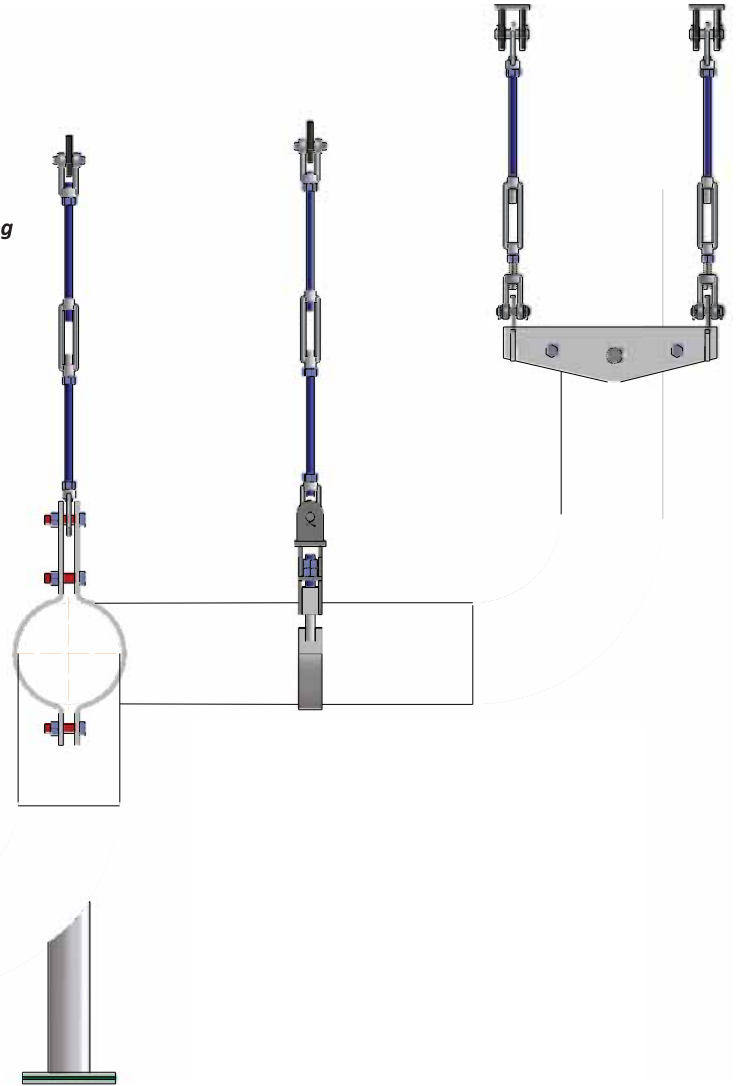

## MODELLER / MODELS

10	11	12	13	14	15
16	17	18	19	20	21
22	23	24	25	26	27

Kod/Code	Boru Çapı/Pipe Dia.	İnç/Inch
11	DN 15	1/2"
13	DN 20	3/4"
15	DN 25	1
17	DN 32	1 1/4"
19	DN 40	1 1/2"
21	DN 50	2
23	DN 65	2 1/2"
25	DN 80	3"
27	DN 100	4"
29	DN 125	5"
31	DN 150	6"
33	DN 200	8"
35	DN 250	10"
37	DN 300	12"
39	DN 350	14"
41	DN 400	16"
43	DN 450	18"
45	DN 500	20"
47	DN 550	22"
49	DN 600	24"
51	DN 650	26"
53	DN 700	28"
55	DN 750	30"
57	DN 800	32"
59	DN 850	34"
61	DN 900	36"
63	DN 1000	40"
65	DN 1050	42"
67	DN 1200	48"

Kod/Code	Metrik/Metric
69	M.10
71	M.12
73	M.16
75	M.20
77	M.24
79	M.27
81	M.30
83	M.36
85	M.42
87	M.48
89	M.56
91	M.68
93	M.72
95	M.80
97	M.90
99	M.100

Kod / Code	Malzeme / Material
0	S 235 JR
1	S 275 JR
2	S 355
3	P265 GH
4	P265 NL
5	16 Mo 3
6	13 CrMo 4.5
7	10 CrMo 9.10
8	304
9	316L

Kod/Code	Kaplama /Coating
0	SIYAH (UNCOATED)
1	ELEKTRO GLV.(E.G)
2	DALDIRMA GLV(HDG)
3	ASTAR(LINING)
4	BOYA (PAINT)

## KODLAMA KLAVUZU / CODING GUIDE

L	F	T	2	1	1	6	1	2
Link ürünü Link product	Ürün grubu Product grup	Ürün modeli Product type	Model Type	Metrik dış aralığı Metric bolt range	Malzeme Material	Yüzey koruma Coating		

## DİŞLİ AKSESUARLAR / THREADED ACCESSORIES

Material / Malzeme : FORGED STEEL  
Standart / Standart : MSS SP 58 Type 17  
Coating / Kaplama : Zinc Plating (elektro)

### KAYNAKSIZ GÖZ SOMUN / WELDLESS EYE NUT

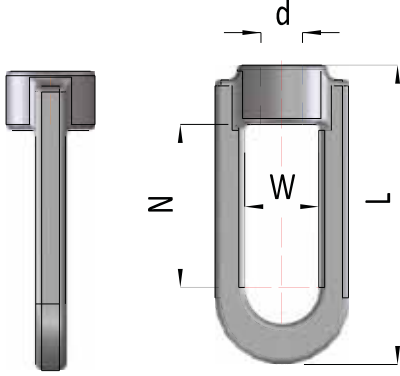

Kod Code	Diş Ölçüsü Thread Size (d)	W	L	N	Dizayn Yüğü Desing Load (kN)
LFT.1069	M.10	17	79	45	2.7
LFT.1071	M.12	17	79	45	6.0
LFT.1073	M.16	25	101	55	13.0
LFT.1075	M.20	29	125	65	18.0
LFT.1077	M.24	35	154	80	26.0
LFT.1079	M.27	38	165	85	30.0
LFT.1081	M.30	42	181	90	40.0
LFT.1083	M.36	47	202	95	60.0
LFT.1085	M.42	52	229	105	90.0
LFT.1087	M.48	62	258	120	120.0

MATERIAL / malzeme : FORGED STEEL  
STANDARD / standart : MSS SP 58 Type 14  
COATING / kaplama : Zinc Plating (elektro)

### DÖVME DEMİR MAŞA / MALLEABLE STEEL CLEVIS

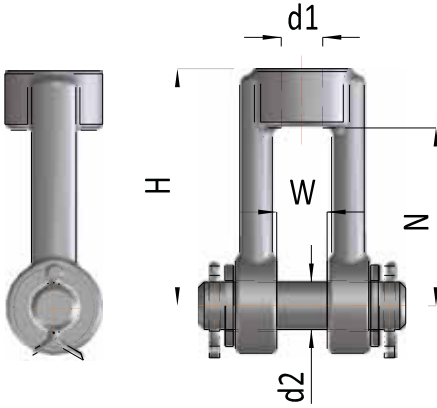

Kod Code	Diş Ölçüsü Thread Size (d1)	W	d2	H	N	Dizayn Yüğü Desing Load (kN)
LFT.1169	M.10	12	12	70	60	2.7
LFT.1171	M.12	12	12	70	60	6.9
LFT.1173	M.16	17	16	80	60	13
LFT.1175	M.20	20	20	90	65	18.0
LFT.1177	M.24	22	24	110	75	26.0
LFT.1179	M.27	25	36	120	80	30.0
LFT.1181	M.30	27	40	130	90	40.0
LFT.1183	M.36	32	45	150	100	60.0
LFT.1185	M.42	37	50	170	110	90.0
LFT.1187	M.48	42	60	180	130	120.0

### GERDİRME / TURNBUCKLE

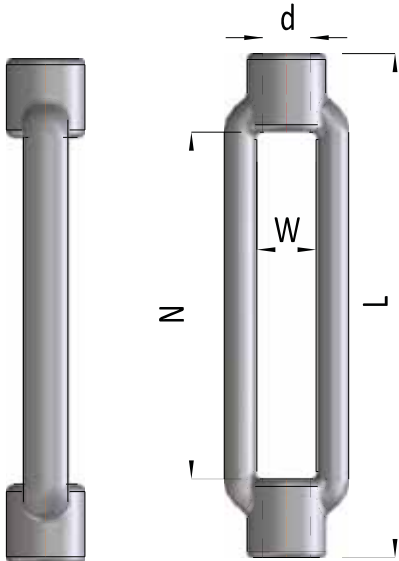

MATERIAL / malzeme : FORGED STEEL  
STANDARD / standart : MSS SP 58 Type 13  
COATING / kaplama : Zinc Plating (elektro)

Kod Code	Diş Ölçüsü Thread Size (d)	W	L	N	Dizayn Yüğü Desing Load (kN)
LFT.1269	M.10	34	130	88	2.7
LFT.1271	M.12	34	130	88	6.0
LFT.1273	M.16	42	170	116	13.0
LFT.1275	M.20	52	200	134	18.0
LFT.1277	M.24	62	250	172	26.0
LFT.1279	M.27	74	270	172	30.0
LFT.1281	M.30	74	270	180	40.0
LFT.1283	M.36	86	290	180	60.0
LFT.1285	M.42	104	330	204	90.0
LFT.1287	M.48	130	330	204	120.0

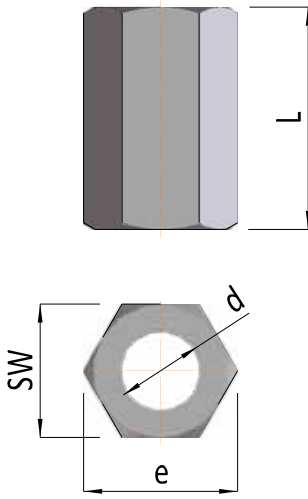
**DIŞLİ AKSESUARLAR / THREADED ACCESSORIES**
**UZATMA SOMUN / COUPLING NUT**

Material / Malzeme :CARBON STELL

Standart / Standart :DIN 6334

Coating / Kaplama :Zinc Coating(elektro)

Kod Code	Diş Ölçüsü Thread Size (d)	e	SW	L	Dizayn Yüğü Desing Load (kN)
LFT.1369	M.10	19	17	30	2.7
LFT.1371	M.12	21	19	36	6.0
LFT.1373	M.16	27	24	48	13.0
LFT.1375	M.20	33.5	30	60	18.0
LFT.1377	M.24	40	36	72	26.0
LFT.1379	M.27	45.5	41	90	40.0
LFT.1381	M.30	51	46	90	60.0
LFT.1383	M.36	61	55	108	90.0
LFT.1385	M.42	72.5	65	120	120.0
LFT.1387	M.48	84	75	135	160.0

Material / Malzeme :CARBON STELL

Standart / Standart :DIN 6330

Coating / Kaplama :Zinc Coating(elektro)

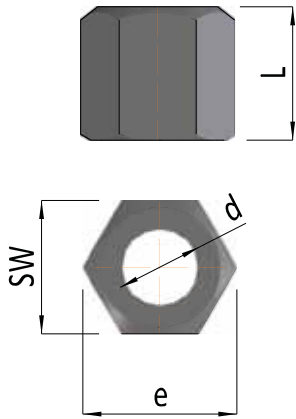
**TAKVİYELİ SOMUN / HEXAGON NUT**

Kod / Code		Diş Ölçüsü Thread Size (d)	e	L	SW
LEFT	RIGHT				
LFT.1469	LFT.3469	M.10	18	15	16
LFT.1471	LFT.3471	M.12	21	18	18
LFT.1473	LFT.3473	M.16	28	24	24
LFT.1475	LFT.3475	M.20	35	30	30
LFT.1477	LFT.3477	M.24	42	36	36
LFT.1479	LFT.3479	M.27	53	40	41
LFT.1481	LFT.3481	M.30	53	45	46
LFT.1483	LFT.3483	M.36	64	54	55
LFT.1485	LFT.3485	M.42	75	63	65
LFT.1487	LFT.3487	M.48	87	72	75

Material / Malzeme :CARBON STELL

Standart / Standart :DIN 934

Coating / Kaplama :Zinc Coating(elektro)

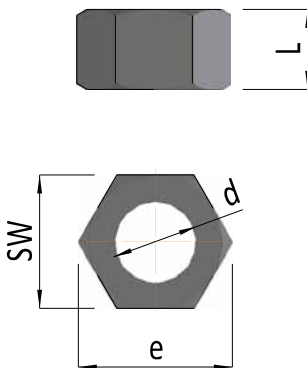
**SOMUN / HEXAGON NUT**

Kod / Code		Diş Ölçüsü Thread Size (d)	e	L	SW
LEFT	RIGHT				
LFT.1569	LFT.3569	M.10	19	8	17
LFT.1571	LFT.3571	M.12	21	10	19
LFT.1573	LFT.3573	M.16	27	13	24
LFT.1575	LFT.3575	M.20	33.5	16	30
LFT.1577	LFT.3577	M.24	40	19	36
LFT.1579	LFT.3579	M.27	45.5	24	41
LFT.1581	LFT.3581	M.30	51	24	46
LFT.1583	LFT.3583	M.36	61	29	55
LFT.1585	LFT.3585	M.42	72.5	34	65
LFT.1587	LFT.3587	M.48	84	38	75

## DİŞLİ AKSESUARLAR / THREADED ACCESSORIES

### KONTRA SOMUN / HEXAGON NUT

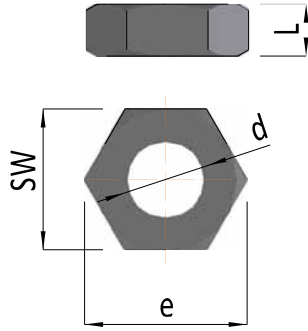

Material / Malzeme :CARBON STELL  
Standart / Standart :DIN 936  
Coating / Kaplama :Zinc Coating(elektro)

Kod / Code		Diş Ölçüsü Thread Size (d)	e	L	SW
LFT.1669	LFT.3669	M.10	19	5	17
LFT.1671	LFT.3671	M.12	21	6	19
LFT.1673	LFT.3673	M.16	27	8	24
LFT.1675	LFT.3675	M.20	33.5	10	30
LFT.1677	LFT.3677	M.24	40	12	36
LFT.1679	LFT.3679	M.27	45.5	13,5	41
LFT.1681	LFT.3681	M.30	51	15	46
LFT.1683	LFT.3683	M.36	61	18	55
LFT.1685	LFT.3685	M.42	72.5	21	65
LFT.1687	LFT.3687	M.48	84	24	75

### GENİŞ PUL / WASHER

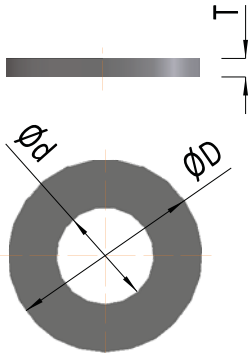

Material / Malzeme :CARBON STELL  
Standart / Standart :DIN 9021 EN ISO 7093  
Coating / Kaplama :Zinc Coating(elektro)

Kod Code	Diş Ölçüsü Thread Size	d	D	T
LFT.1769	M.10	10,5	30	3
LFT.1771	M.12	13	37	3
LFT.1773	M.16	17	50	4
LFT.1775	M.20	22	60	4
LFT.1777	M.24	26	72	5
LFT.1779	M.27	30	82	5
LFT.1781	M.30	33	92	6
LFT.1783	M.36	39	110	8
LFT.1785	M.42	45	135	10
LFT.1787	M.48	52	155	12

### YAYLI RONDELA / SPRING LOCK WASHER

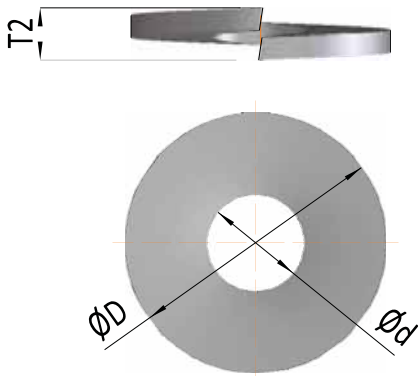

Material / Malzeme :CARBON STELL  
Standart / Standart :DIN 127/B  
Coating / Kaplama :Zinc Coating(elektro)

Kod Code	Diş Ölçüsü Thread Size	Ød	ØD	T2
LFT.1869	M.10	10,7	18,1	2,2
LFT.1871	M.12	12,7	21,1	2,5
LFT.1873	M.16	17	27,4	3,5
LFT.1875	M.20	21,2	33,6	4
LFT.1877	M.24	25,5	40	5
LFT.1879	M.27	28,5	43	5
LFT.1881	M.30	31,7	48,2	6
LFT.1883	M.36	37,7	58,2	6
LFT.1885	M.42	43,7	68,2	7
LFT.1887	M.48	50,5	75	7

**DİŞLİ AKSESUARLAR / THREADED ACCESSORIES**

Material / Malzeme : CARBON STEEL

Standart / Standart : DIN 436

Coating / Kaplama : Zinc Coating(elektro)

KARE PUL / SQUARE WASHER

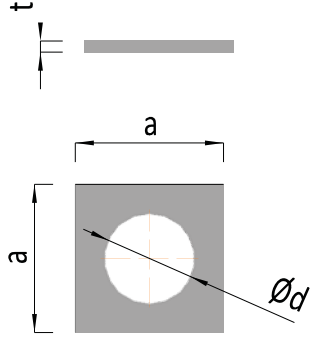

Kode Code	Diş Ölçüsü Thread Size	Ød	a	t
LFT.1969	M.10	11	30	3
LFT.1971	M.12	13,5	40	4
LFT.1973	M.16	17,5	50	5
LFT.1975	M.20	22	60	5
LFT.1977	M.24	26	80	6
LFT.1979	M.27	30	90	6
LFT.1981	M.30	33	95	6
LFT.1983	M.36	39	110	8
LFT.1985	M.42	45	135	8
LFT.1987	M.48	52	150	10

Material / Malzeme : CARBON STEEL

Standart / Standart :

Coating / Kaplama : Zinc Coating(elektro)

SAĞ-SOL DİŞ SAPLAMA / LEFT-RIGHT ROD

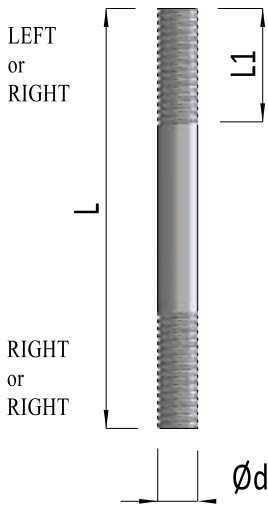

Kod / Code		Diş Ölçüsü Thread Size (d)	L	L1	Dizayn Yüğü Desing Load (kN)
Left-Right	Right-Right				
LFT.2069	LFT.4069	M.10	250	130	2.7
LFT.2071	LFT.4071	M.12	250	130	6.0
LFT.2073	LFT.4073	M.16	250	130	13.0
LFT.2075	LFT.4075	M.20	250	130	18.0
LFT.2077	LFT.4077	M.24	350	190	26.0
LFT.2079	LFT.4079	M.27	350	190	40.0
LFT.2081	LFT.4081	M.30	350	190	60.0
LFT.2083	LFT.4083	M.36	350	190	90.0
LFT.2085	LFT.4085	M.42	450	220	120.0
LFT.2087	LFT.4087	M.48	450	220	160.0

Material / Malzeme : CARBON STEEL

Standart / Standart : DIN 975

Coating / Kaplama : Zinc Coating(elektro)

ROT / ROD

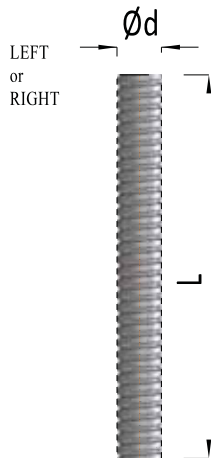

Kod / Code		Diş Ölçüsü Thread Size (d)	Min-Max (mm)	Dizayn Yüğü Desing Load (kN)
RIGHT	LEFT			
LFT.2169	LFT.4169	M.10	500-3000	3,66
LFT.2171	LFT.4171	M.12	500-3000	5,35
LFT.2173	LFT.4173	M.16	500-3000	10,20
LFT.2175	LFT.4175	M.20	500-3000	16,00
LFT.2177	LFT.4177	M.24	500-3000	23,10
LFT.2179	LFT.4179	M.27	500-3000	31,50
LFT.2181	LFT.4181	M.30	500-3000	37,20
LFT.2183	LFT.4183	M.36	500-3000	54,50
LFT.2185	LFT.4185	M.42	500-3000	75,20
LFT.2187	LFT.4187	M.48	500-3000	92,30

## KAYNAK BAĞLANTI ELAMANLARI / WELDING CONNECTION ELEMENTS

KİRİŞİ PLAKASI / BEAM EYE PLATE

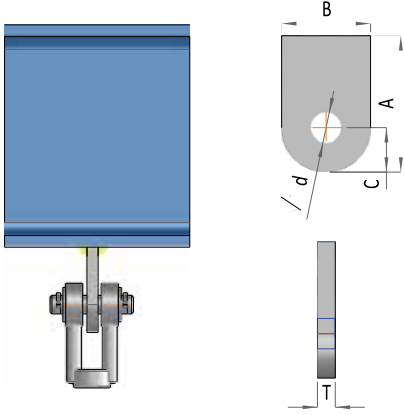

Material / Malzeme :CARBON STELL

Standart / Standart :MSS SP-69

Coating / Kaplama :Zinc Coating(elektro)

Kod Code	Diş Ölçüsü Thread Size	d	A	B	C	T	Dizayn Yüğü Desing Load (kN)
LFK.2269	M.10	11	58	30	18	6	3,8
LFK.2271	M.12	13	67	35	22	8	5,6
LFK.2273	M.16	18	78	45	28	10	10,4
LFK.2275	M.20	22	92	60	37	12	16,3
LFK.2277	M.24	27	100	65	40	15	23,6
LFK.2279	M.27	30	110	70	45	15	30,5
LFK.2281	M.30	35	120	80	50	25	37,5
LFK.2283	M.36	42	140	90	50	30	54,6
LFK.2285	M.42	48	165	100	65	30	74,8
LFK.2287	M.48	54	180	120	70	30	98,2

Material / Malzeme :CARBON STELL

Standart / Standart :MSS SP-69

Coating / Kaplama :Zinc Coating(elektro)

KAYNAKLI MAŞA / WELD ON CLEVIS

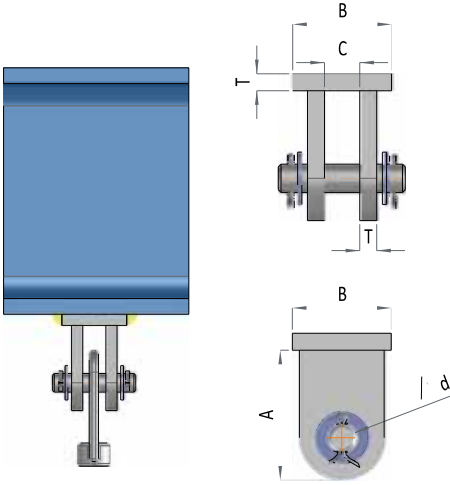

Kod Code	Diş Ölçüsü Thread Size	d	A	B	C	T	Dizayn Yüğü Desing Load (kN)
LFK.2369	M.10	11	58	45	18	6	3,8
LFK.2371	M.12	13	67	50	22	8	5,6
LFK.2373	M.16	18	78	65	28	10	10,4
LFK.2375	M.20	22	92	85	37	12	16,3
LFK.2377	M.24	27	100	100	40	15	23,6
LFK.2379	M.27	30	110	100	45	15	30,5
LFK.2381	M.30	35	120	130	50	25	37,5
LFK.2383	M.36	42	140	160	65	30	54,6
LFK.2385	M.42	48	165	160	75	30	74,8
LFK.2387	M.48	54	180	200	80	30	98,2

Material / Malzeme :CARBON STELL

Standart / Standart :MSS SP-69

Coating / Kaplama :Zinc Coating(elektro)

KİRİŞ U PLAKASI / BEAM U PLATE

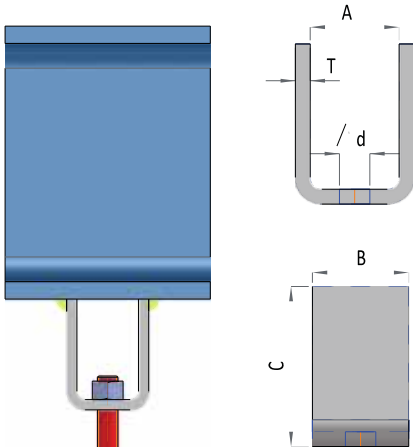

Kod Code	Diş Ölçüsü Thread Size	d	A	B	C	T	Dizayn Yüğü Desing Load (kN)
LFK.2469	M.10	11	35	50	75	6	3,8
LFK.2471	M.12	13	40	50	75	6	5,6
LFK.2473	M.16	18	45	50	75	6	10,4
LFK.2475	M.20	22	60	65	110	10	16,3
LFK.2477	M.24	27	70	80	115	10	23,6
LFK.2479	M.27	30	80	90	120	12	30,5
LFK.2481	M.30	35	90	100	130	15	37,5
LFK.2483	M.36	42	110	130	140	20	54,6
LFK.2485	M.42	48	120	130	200	20	74,8
LFK.2487	M.48	54	140	150	210	25	98,2

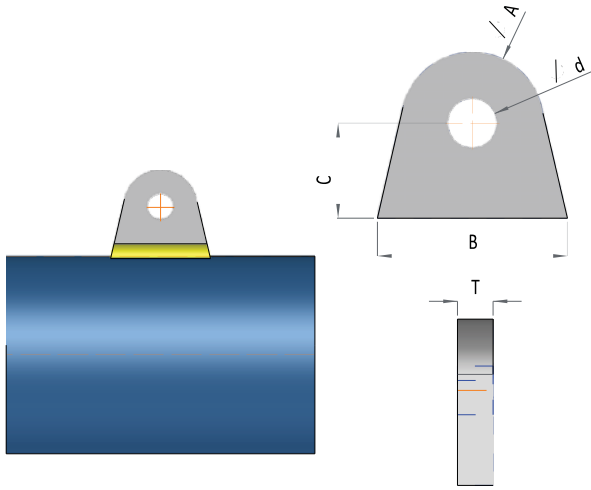

**KAYNAK BAĞLANTI ELAMANLARI / WELDING CONNECTION ELEMENTS**
**YATAY BORU I PLAKASI / HORIZONTAL PIPE EYE PLATE**

Material / Malzeme :CARBON STEEL

Standart / Standart :MSS SP-69

Coating / Kaplama :Zinc Coating(elektro)

Kod Code	Diş Ölçüsü Thread Size	d	A	B	C	T	Dizayn Yüğü Desing Load (kN)
LFK.2569	M.10	11	30	50	75	6	3,8
LFK.2571	M.12	13	35	50	75	6	5,6
LFK.2573	M.16	18	40	50	75	6	10,4
LFK.2575	M.20	22	60	65	110	10	16,3
LFK.2577	M.24	27	70	80	115	10	23,6
LFK.2579	M.27	30	75	90	120	12	30,5
LFK.2581	M.30	35	85	100	130	15	37,5
LFK.2583	M.36	40	110	130	140	20	54,6
LFK.2585	M.42	46	120	130	200	20	74,8
LFK.2587	M.48	52	140	150	210	25	98,2

Material / Malzeme :CARBON STEEL

Standart / Standart :MSS SP-69

Coating / Kaplama :Zinc Coating(elektro)

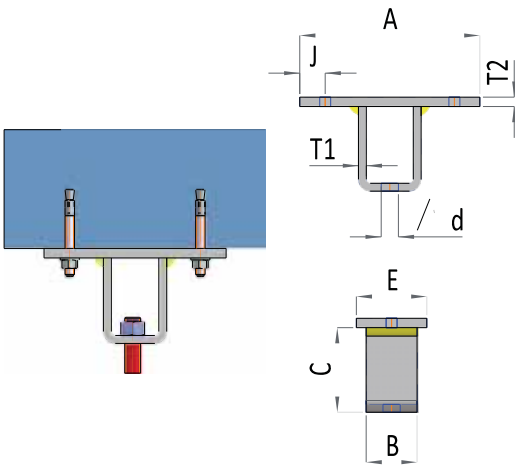
**TAVAN TESPİT PLAKASI / CEILING FIXING PLATE**

Kod Code	Diş Ölçüsü Thread Size	d	K	B	C	T1	E	J	T2	Dizayn Yüğü Desing Load (kN)
LFK.2669	M.10	11	150	50	75	6	70	25	8	3,8
LFK.2671	M.12	13	180	50	75	6	70	25	8	5,6
LFK.2673	M.16	18	200	50	75	6	70	25	8	10,4
LFK.2675	M.20	22	200	65	110	10	90	30	12	16,3
LFK.2677	M.24	27	225	80	115	10	110	30	12	23,6
LFK.2679	M.27	30	250	90	120	12	120	40	15	30,5
LFK.2681	M.30	35	300	100	130	16	150	50	20	37,5
LFK.2683	M.36	40	300	130	140	20	180	50	25	54,6
LFK.2685	M.42	46	370	130	200	20	180	60	25	74,8
LFK.2687	M.48	52	370	150	210	25	220	60	30	98,2

Material / Malzeme :CARBON STEEL

Standart / Standart :MSS SP-69

Coating / Kaplama :Zinc Coating(elektro)

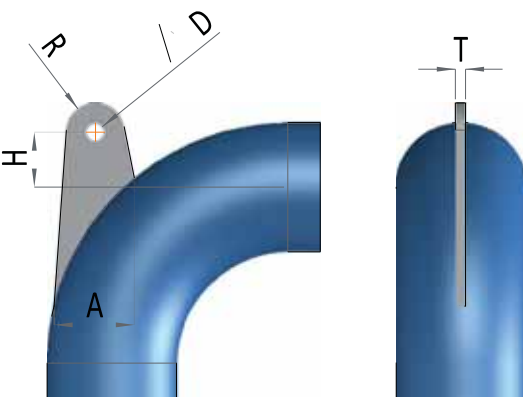
**DİRSEK I PLAKASI / ELBOW EYE PLATE**

Kod Code	Diş Ölçüsü Thread Size	D	A	H	R	T	Dizayn Yüğü Desing Load (kN)
LFK.2769	M.10	11	55	75	20	8	3,8
LFK.2771	M.12	13	55	75	20	8	5,6
LFK.2773	M.16	18	65	75	25	10	10,4
LFK.2775	M.20	22	90	80	35	12	16,3
LFK.2777	M.24	27	105	80	40	15	23,6
LFK.2779	M.27	30	115	85	45	15	30,5
LFK.2781	M.30	35	130	95	50	20	37,5
LFK.2783	M.36	40	145	95	55	25	54,6
LFK.2785	M.42	46	160	100	65	25	74,8
LFK.2787	M.48	52	200	100	80	25	98,2

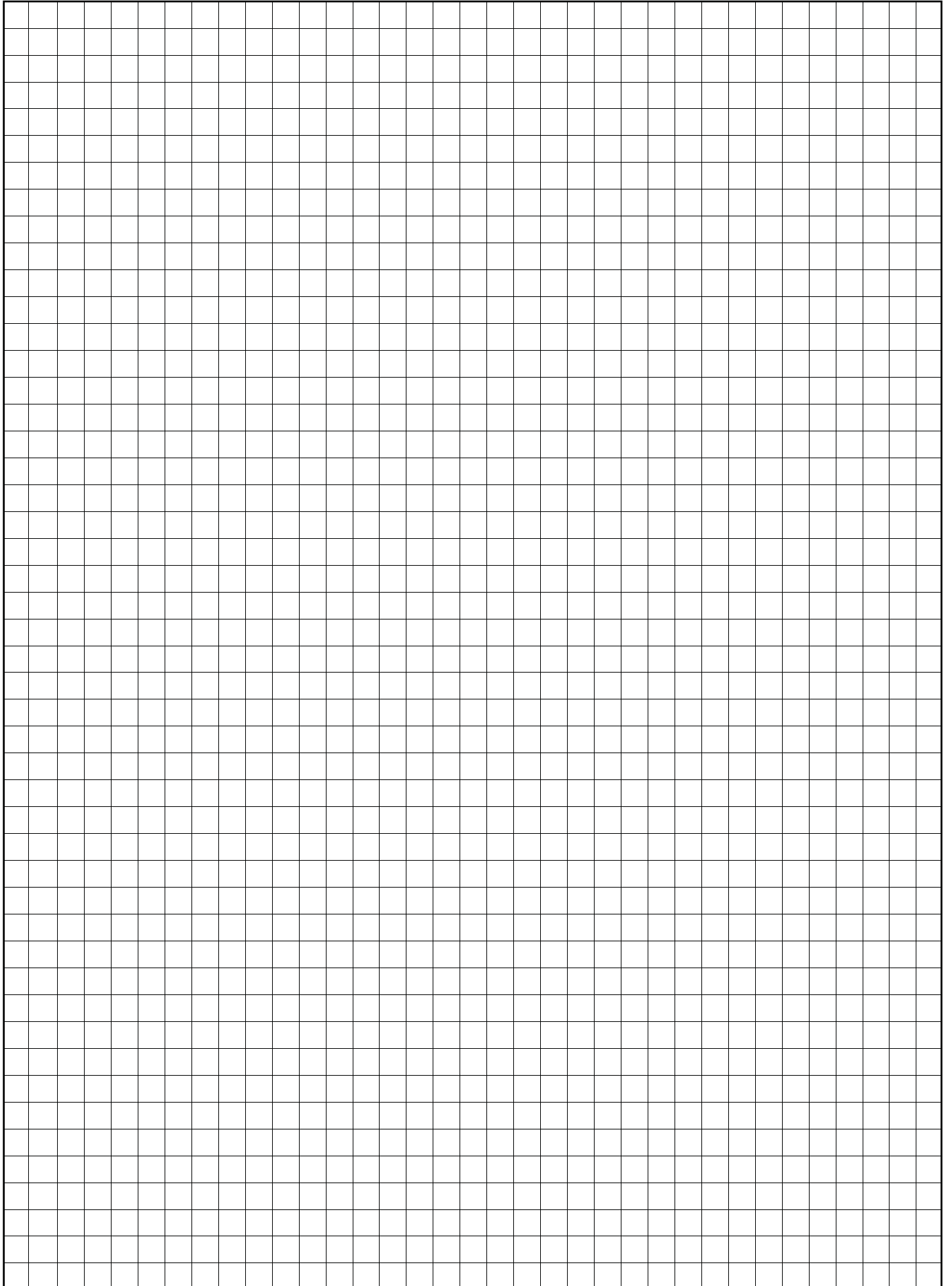

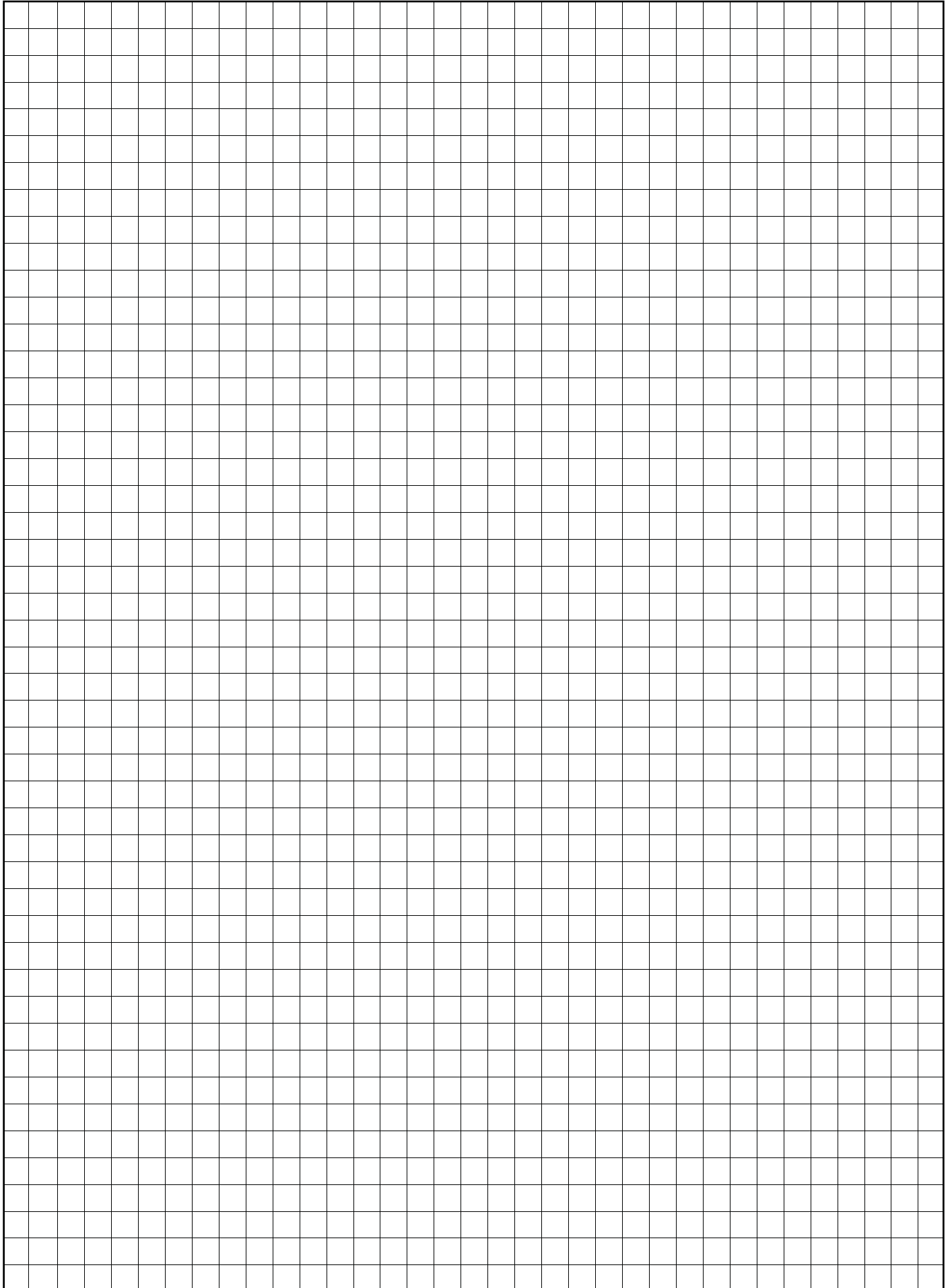

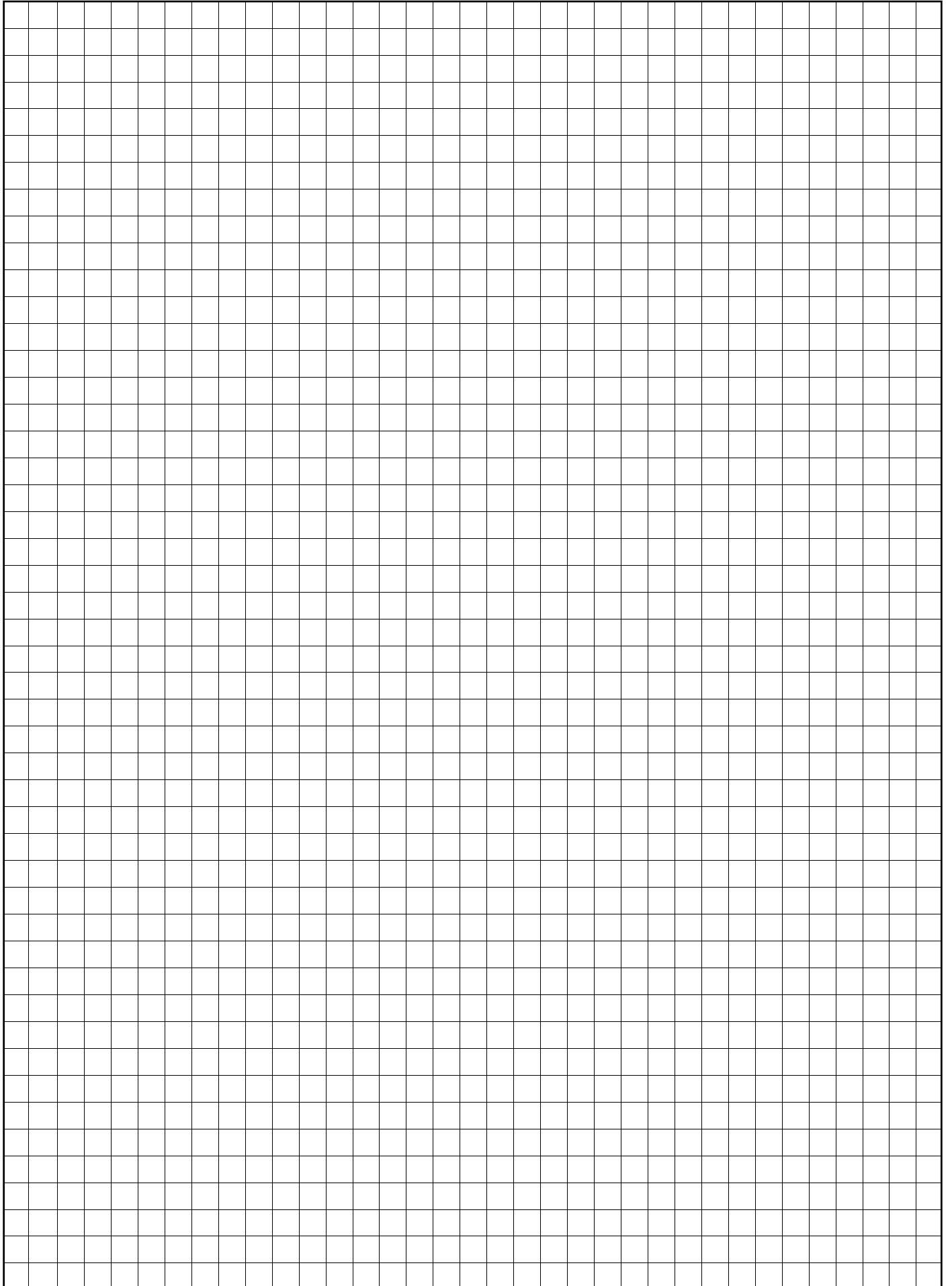

# Diğer Sistem Çözümlerimiz

## Our Other System Solutions



Tesisat Bağlantı Sistemleri  
*Installation Systems*



Havalandırma Sistemleri  
*Ventilation Systems*



Ses ve Titreşim Yalıtımı Sistemleri  
*Sound and Vibration Isolation Systems*



Sismik Sınırlama Sistemleri  
*Seismic Restraint Systems*

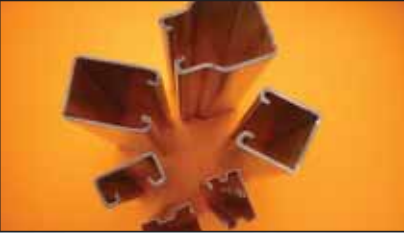

Modüler Profil Sistemleri  
*Modular Support Systems*



Endüstriyel Askı ve Destek Sistemleri  
*Industrial Hanger and Support Systems*



Yapı Tespit Sistemleri  
*Anchor and Fixing Systems*



Cephe Sistemleri  
*Facade Systems*

**Partnerlerimiz** *Partners*





## **LINK YAPI SANAYİ ve TİCARET A.Ş.**

G.O.S.B. 1000. Sokak No: 1016 Çayırova / Kocaeli  
T: +90 444 54 65 F: +90 262 751 33 23  
info@linkyapi.com.tr

Tepe Prime C Blok No: 53 Eskişehir Devlet Yolu 9. km  
Çankaya / Ankara  
T: +90 312 220 40 24-25 F: +90 312 220 40 26

